

TOPLA TRACTION BATTERIES

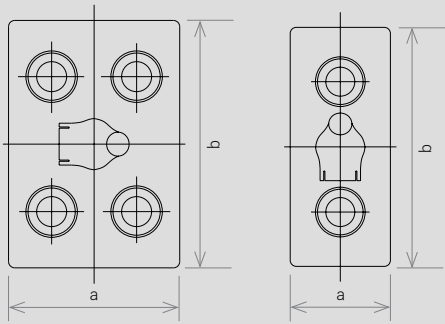

topla

DIN
DIN-S
BS
PzV
PzVB
PzRM



IN ORDER THAT THE BATTERIES WOULD MEET ALL YOUR DEMANDS, WE KINDLY ASK YOU TO ENCLOSE THE FOLLOWING DATA WITH YOUR ORDER:

- battery voltage
- capacity of the battery at a five-hour discharge rate
- dimensions of the battery tray
- designation and type of the electric machine
- any special demands
- a battery drawing (when possible)

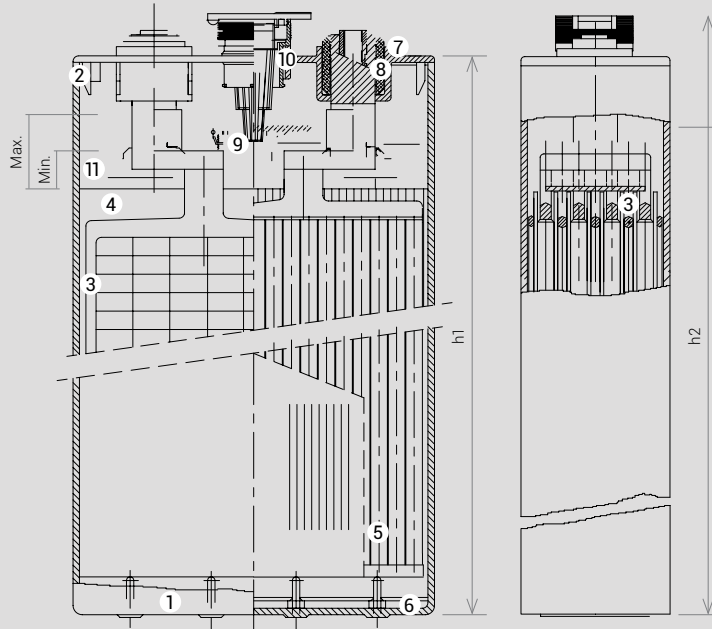
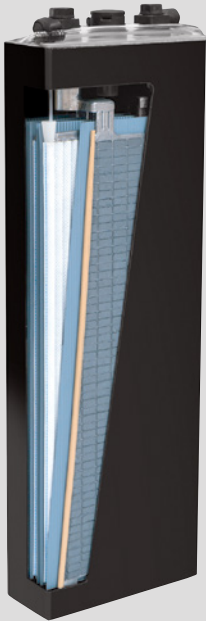

- 1 Polypropilene container
- 2 Polypropilene cover
- 3 Negative grid Plate
- 4 Microporous separator
- 5 Positive armoured tube Plate
- 6 Settling rib
- 7 Terminal post
- 8 Rubber sealing
- 9 Cell plug Ø 35,5
- 10 Plug sealing Ø 35,5
- 11 Electrolyte

IN CASE OF PROBLEMS WITH ORDERING WE WILL BE GLAD TO ADVISE AND ASSIST YOU IN THE SELECTION OF THE SUITABLE TYPE OF BATTERY.

All measures and weights are within standard production tolerances. Electrical values are approximate. Technical modifications are reserved without prior notice.

TERMINAL POST WELDED VERSION

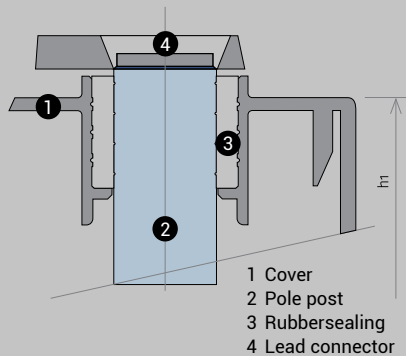

TERMINAL POST BOLTED VERSION

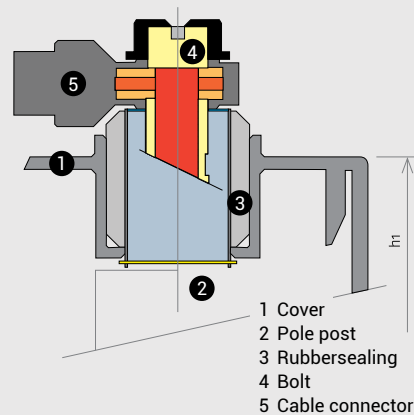

BOTH VERSIONS ARE BEING MANUFACTURED:

• DRY-CHARGED VERSION:

a battery / cell has to be filled up with an electrolyte and supplementary charged before use. The Plates are already formed and in special process protected against oxidation. They can be stored up to two years.

• ELECTROLYTE-CHARGED:

a battery / cell can be installed immediately, because it is already filled up with electrolyte and electrically charged as well.

DIN STANDARD CHARACTERISTIC DATA

Electrolyte density at 30 °C: 1,29 ± 0,01 kg/l. Weight tolerance is ± 5 %.

Cells from 7 to 10 PzS types are available with 2 and 4 poles. For 4 poles, please specify in your order.

10 PzS 1400 L, 10 PzS 1550 L and all 12 PzS cells are available with 4 poles only. Cells available only with 4 poles are signed with *.

50Ah/plate

h1 = 282, h2 = 305 mm | length = b = 198 mm

CELL TYPE	TOPLA DESIGNATION	CAPACITY 5h	WIDTH mm	WEIGHT with acid	WEIGHT dry (kg)
2 PzS 100 L	2 Pg 190 L	100	47	6,8	5,7
3 PzS 150 L	3 Pg 190 L	150	65	9,6	7,7
4 PzS 200 L	4 Pg 190 L	200	83	12,4	9,9
5 PzS 250 L	5 Pg 190 L	250	101	15,3	12,2
6 PzS 300 L	6 Pg 190 L	300	119	18,2	14,5
7 PzS 350 L	7 Pg 190 L	350	137	21,1	16,7
8 PzS 400 L	8 Pg 190 L	400	155	24,0	19,0
9 PzS 450 L	9 Pg 190 L	450	173	26,9	21,3
10 PzS 500 L	10 Pg 190 L	500	191	29,8	23,6
12 PzS 600 L *	12 Pg 190 L	600	227	35,9	28,4

80Ah/plate

h1 = 402, h2 = 425 mm | length = b = 198 mm

CELL TYPE	TOPLA DESIGNATION	CAPACITY 5h	WIDTH mm	WEIGHT with acid	WEIGHT dry (kg)
2 PzS 160 L	2 Pg 310 L	160	47	10,2	8,1
3 PzS 240 L	3 Pg 310 L	240	65	14,5	11,2
4 PzS 320 L	4 Pg 310 L	320	83	18,7	14,6
5 PzS 400 L	5 Pg 310 L	400	101	22,9	17,9
6 PzS 480 L	6 Pg 310 L	480	119	27,1	21,3
7 PzS 560 L	7 Pg 310 L	560	137	31,3	24,7
8 PzS 640 L	8 Pg 310 L	640	155	35,5	28,0
9 PzS 720 L	9 Pg 310 L	720	173	39,7	31,4
10 PzS 800 L	10 Pg 310 L	800	191	43,9	34,7
12 PzS 960 L *	12 Pg 310 L	960	227	52,6	41,8

105Ah/plate

h1 = 515, h2 = 538 mm | length = b = 198 mm

CELL TYPE	TOPLA DESIGNATION	CAPACITY 5h	WIDTH mm	WEIGHT with acid	WEIGHT dry (kg)
2 PzS 210 L	2 Pg 425 L	210	47	13,3	10,3
3 PzS 315 L	3 Pg 425 L	315	65	18,3	14,4
4 PzS 420 L	4 Pg 425 L	420	83	23,7	18,6
5 PzS 525 L	5 Pg 425 L	525	101	29,1	22,9
6 PzS 630 L	6 Pg 425 L	630	119	34,5	27,1
7 PzS 735 L	7 Pg 425 L	735	137	39,9	31,4
8 PzS 840 L	8 Pg 425 L	840	155	45,3	35,6
9 PzS 945 L	9 Pg 425 L	945	173	50,7	39,9
10 PzS 1050 L	10 Pg 425 L	1050	191	56,4	44,5
12 PzS 1260 L *	12 Pg 425 L	1260	227	67,2	53,0

125Ah/plate

h1 = 570, h2 = 593 mm | length = b = 198 mm

CELL TYPE	TOPLA DESIGNATION	CAPACITY 5h	WIDTH mm	WEIGHT with acid	WEIGHT dry (kg)
2 PzS 250 L	2 Pg 480 L	250	47	14,7	11,6
3 PzS 375 L	3 Pg 480 L	375	65	20,7	16,2
4 PzS 500 L	4 Pg 480 L	500	83	26,9	21,1
5 PzS 625 L	5 Pg 480 L	625	101	33,1	26,0
6 PzS 750 L	6 Pg 480 L	750	119	39,3	30,9
7 PzS 875 L	7 Pg 480 L	875	137	45,5	35,8
8 PzS 1000 L	8 Pg 480 L	1000	155	51,7	40,7
9 PzS 1125 L	9 Pg 480 L	1125	173	58,2	45,9
10 PzS 1250 L	10 Pg 480 L	1250	191	64,4	50,8
12 PzS 1500 L *	12 Pg 480 L	1500	227	76,8	60,6

155Ah/plate

h1 = 720, h2 = 743 mm | length = b = 198 mm

CELL TYPE	TOPLA DESIGNATION	CAPACITY 5h	WIDTH mm	WEIGHT with acid	WEIGHT dry (kg)
2 PzS 310 L	2 Pg 590 L	310	47	18,8	14,9
3 PzS 465 L	3 Pg 590 L	465	65	26,1	20,6
4 PzS 620 L	4 Pg 590 L	620	83	33,5	26,7
5 PzS 775 L	5 Pg 590 L	775	101	41,1	32,9
6 PzS 930 L	6 Pg 590 L	930	119	48,9	39,0
7 PzS 1085 L	7 Pg 590 L	1085	137	56,7	45,1
8 PzS 1240 L	8 Pg 590 L	1240	155	64,5	51,3
9 PzS 1395 L	9 Pg 590 L	1395	173	72,8	57,8
10 PzS 1550 L *	10 Pg 590 L	1550	191	80,6	64,0
12 PzS 1860 L *	12 Pg 590 L	1860	227	96,2	76,2

60Ah/plate

h1 = 340, h2 = 363 mm | length = b = 198 mm

CELL TYPE	TOPLA DESIGNATION	CAPACITY 5h	WIDTH mm	WEIGHT with acid	WEIGHT dry (kg)
2 PzS 120 L	2 Pg 250 L	120	47	8,5	6,5
3 PzS 180 L	3 Pg 250 L	180	65	11,9	9,2
4 PzS 240 L	4 Pg 250 L	240	83	15,4	11,9
5 PzS 300 L	5 Pg 250 L	300	101	18,9	14,6
6 PzS 360 L	6 Pg 250 L	360	119	22,4	17,2
7 PzS 420 L	7 Pg 250 L	420	137	25,9	19,9
8 PzS 480 L	8 Pg 250 L	480	155	29,4	22,6
9 PzS 540 L	9 Pg 250 L	540	173	32,9	25,2
10 PzS 600 L	10 Pg 250 L	600	191	36,4	27,9
12 PzS 720 L *	12 Pg 250 L	720	227	43,7	33,6

90Ah/plate

h1 = 472, h2 = 495 mm | length = b = 198 mm

CELL TYPE	TOPLA DESIGNATION	CAPACITY 5h	WIDTH mm	WEIGHT with acid	WEIGHT dry (kg)
2 PzS 180 L	2 Pg 360 L	180	47	11,6	9,1
3 PzS 270 L	3 Pg 360 L	270	65	16,6	12,8
4 PzS 360 L	4 Pg 360 L	360	83	21,4	16,6
5 PzS 450 L	5 Pg 360 L	450	101	26,2	20,5
6 PzS 540 L	6 Pg 360 L	540	119	31,0	24,4
7 PzS 630 L	7 Pg 360 L	630	137	35,8	28,2
8 PzS 720 L	8 Pg 360 L	720	155	40,6	32,1
9 PzS 810 L	9 Pg 360 L	810	173	45,4	35,9
10 PzS 900 L	10 Pg 360 L	900	191	50,2	39,8
12 PzS 1080 L *	12 Pg 360 L	1080	227	60,1	47,8

115Ah/plate

h1 = 545, h2 = 568 mm | length = b = 198 mm

CELL TYPE	TOPLA DESIGNATION	CAPACITY 5h	WIDTH mm	WEIGHT with acid	WEIGHT dry (kg)
2 PzS 230 L	2 Pg 445 L	230	47	14,0	10,8
3 PzS 345 L	3 Pg 445 L	345	65	19,8	15,3
4 PzS 460 L	4 Pg 445 L	460	83	25,6	19,9
5 PzS 575 L	5 Pg 445 L	575	101	31,4	24,8
6 PzS 690 L	6 Pg 445 L	690	119	37,2	29,6
7 PzS 805 L	7 Pg 445 L	805	137	43,0	34,5
8 PzS 920 L	8 Pg 445 L	920	155	48,8	39,3
9 PzS 1035 L	9 Pg 445 L	1035	173	54,9	44,5
10 PzS 1150 L	10 Pg 445 L	1150	191	60,7	49,3
12 PzS 1380 L *	12 Pg 445 L	1380	227	72,3	59,0

140Ah/plate

h1 = 686, h2 = 709 mm | length = b = 198 mm

CELL TYPE	TOPLA DESIGNATION	CAPACITY 5h	WIDTH mm	WEIGHT with acid	WEIGHT dry (kg)
2 PzS 280 L	2 Pg 555 L	280	47	18,3	14,4
3 PzS 420 L	3 Pg 555 L	420	65	25,3	19,4
4 PzS 560 L	4 Pg 555 L	560	83	32,2	25,1
5 PzS 700 L	5 Pg 555 L	700	101	39,5	30,9
6 PzS 840 L	6 Pg 555 L	840	119	46,7	36,6
7 PzS 980 L	7 Pg 555 L	980	137	54,0	42,3
8 PzS 1120 L	8 Pg 555 L	1120	155	61,2	48,0
9 PzS 1260 L	9 Pg 555 L	1260	173	68,8	54,1
10 PzS 1400 L *	10 Pg 555 L	1400	191	76,0	59,8
12 PzS 1680 L *	12 Pg 555 L	1680	227	90,5	71,3



DIN S STANDARD CHARACTERISTIC DATA

Electrolyte density at 30 °C: 1,29 ± 0,01 kg/l. Weight tolerance is ± 5 %.
Cells from 7 to 10 PzS types are available with 2 and 4 poles. For 4 poles, please specify in your order. 10 PzS 1450 S and all 12 PzS cells are available with 4 poles only.
 Cells available only with 4 poles are signed with *.

110Ah/plate

h1 = 545, h2 = 568 mm | length = b = 198 mm

CELL TYPE	TOPLA DESIGNATION	CAPACITY 5h	WIDTH mm	WEIGHT with acid	WEIGHT dry (kg)
2 PzS 220 S	2 Pg 425 S	220	47	13,9	10,4
3 PzS 330 S	3 Pg 425 S	330	65	19,1	14,5
4 PzS 440 S	4 Pg 425 S	440	83	24,4	18,7
5 PzS 550 S	5 Pg 425 S	550	101	29,8	23,1
6 PzS 660 S	6 Pg 425 S	660	119	35,2	27,3
7 PzS 770 S	7 Pg 425 S	770	137	40,6	31,6
8 PzS 880 S	8 Pg 425 S	880	155	46,0	35,8
9 PzS 990 S	9 Pg 425 S	990	173	51,4	40,1
10 PzS 1100 S	10 Pg 425 S	1100	191	57,1	44,6
12 PzS 1320 S *	12 Pg 425 S	1320	227	67,9	53,2

135Ah/plate

h1 = 686, h2 = 709 mm | length = b = 198 mm

CELL TYPE	TOPLA DESIGNATION	CAPACITY 5h	WIDTH mm	WEIGHT with acid	WEIGHT dry (kg)
2 PzS 270 S	2 Pg 530 S	270	47	18,1	14,4
3 PzS 405 S	3 Pg 530 S	405	65	25,0	18,6
4 PzS 540 S	4 Pg 530 S	540	83	31,9	24,1
5 PzS 675 S	5 Pg 530 S	675	101	38,8	29,5
6 PzS 810 S	6 Pg 530 S	810	119	45,7	34,9
7 PzS 945 S	7 Pg 530 S	945	137	52,6	40,4
8 PzS 1080 S	8 Pg 530 S	1080	155	59,5	45,8
9 PzS 1215 S	9 Pg 530 S	1215	173	66,7	51,6
10 PzS 1350 S	10 Pg 530 S	1350	191	73,6	57,0
12 PzS 1620 S *	12 Pg 530 S	1620	227	87,4	67,9

120Ah/plate

h1 = 570, h2 = 593 mm | length = b = 198 mm

CELL TYPE	TOPLA DESIGNATION	CAPACITY 5h	WIDTH mm	WEIGHT with acid	WEIGHT dry (kg)
2 PzS 240 S	2 Pg 445 S	240	47	14,3	10,9
3 PzS 360 S	3 Pg 445 S	360	65	20,2	15,4
4 PzS 480 S	4 Pg 445 S	480	83	26,0	20,0
5 PzS 600 S	5 Pg 445 S	600	101	31,8	24,8
6 PzS 720 S	6 Pg 445 S	720	119	37,6	29,7
7 PzS 840 S	7 Pg 445 S	840	137	43,4	34,6
8 PzS 960 S	8 Pg 445 S	960	155	49,2	39,4
9 PzS 1080 S	9 Pg 445 S	1080	173	55,3	44,6
10 PzS 1200 S	10 Pg 445 S	1200	191	61,1	49,4
12 PzS 1440 S *	12 Pg 445 S	1440	227	72,7	59,1

145Ah/plate

h1 = 720, h2 = 743 mm | length = b = 198 mm

CELL TYPE	TOPLA DESIGNATION	CAPACITY 5h	WIDTH mm	WEIGHT with acid	WEIGHT dry (kg)
2 PzS 290 S	2 Pg 555 S	290	47	18,5	14,7
3 PzS 435 S	3 Pg 555 S	435	65	25,8	19,7
4 PzS 580 S	4 Pg 555 S	580	83	32,4	25,4
5 PzS 725 S	5 Pg 555 S	725	101	39,7	31,2
6 PzS 870 S	6 Pg 555 S	870	119	47,0	36,9
7 PzS 1015 S	7 Pg 555 S	1015	137	54,3	42,7
8 PzS 1160 S	8 Pg 555 S	1160	155	61,6	48,4
9 PzS 1305 S	9 Pg 555 S	1305	173	69,2	54,5
10 PzS 1450 S *	10 Pg 555 S	1450	191	76,5	60,2
12 PzS 1740 S *	12 Pg 555 S	1740	227	91,1	71,7



BS STANDARD CHARACTERISTIC DATA

Electrolyte density at 30 °C: 1,29 ± 0,01 kg/l. Weight tolerance is ± 5 %.

Cells from 9 to 11 PzB types are available with 4 poles only.

Cells available only with 4 poles are signed with *.

23Ah/plate

h1 = 216, h2 = 240 mm | length = b = 157,5 mm

CELL TYPE	TOPLA DESIGNATION	CAPACITY 5h	WIDTH mm	WEIGHT with acid	WEIGHT dry (kg)
2 PzB 46	2 Pgi 135	46	45	3,7	3,0
3 PzB 69	3 Pgi 135	69	61	5,4	4,2
4 PzB 92	4 Pgi 135	92	77	6,9	5,4
5 PzB 115	5 Pgi 135	115	93	8,4	6,6
6 PzB 138	6 Pgi 135	138	109	10,0	7,8
7 PzB 161	7 Pgi 135	161	125	11,6	9,0
8 PzB 184	8 Pgi 135	184	141	13,2	10,2
9 PzB 207 *	9 Pgi 135	207	157	15,3	11,9
10 PzB 230 *	10 Pgi 135	230	173	16,9	13,1
11 PzB 253 *	11 Pgi 135	253	189	18,4	14,3

32Ah/plate

h1 = 260, h2 = 284 mm | length = b = 157,5 mm

CELL TYPE	TOPLA DESIGNATION	CAPACITY 5h	WIDTH mm	WEIGHT with acid	WEIGHT dry (kg)
2 PzB 64	2 Pgi 190	64	45	5,1	4,0
3 PzB 96	3 Pgi 190	96	61	7,1	5,6
4 PzB 128	4 Pgi 190	128	77	9,2	7,2
5 PzB 160	5 Pgi 190	160	93	11,3	8,8
6 PzB 192	6 Pgi 190	192	109	13,2	10,3
7 PzB 224	7 Pgi 190	224	125	15,0	11,7
8 PzB 256	8 Pgi 190	256	141	16,8	13,1
9 PzB 288 *	9 Pgi 190	288	157	19,1	14,9
10 PzB 320 *	10 Pgi 190	320	173	20,9	16,3
11 PzB 352 *	11 Pgi 190	352	189	22,7	17,7

42Ah/plate

h1 = 326, h2 = 350 mm | length = b = 157,5 mm

CELL TYPE	TOPLA DESIGNATION	CAPACITY 5h	WIDTH mm	WEIGHT with acid	WEIGHT dry (kg)
2 PzB 84	2 Pgi 250	84	45	6,9	5,4
3 PzB 126	3 Pgi 250	126	61	9,4	7,3
4 PzB 168	4 Pgi 250	168	77	11,9	9,3
5 PzB 210	5 Pgi 250	210	93	14,5	11,3
6 PzB 252	6 Pgi 250	252	109	17,3	13,5
7 PzB 294	7 Pgi 250	294	125	20,0	15,6
8 PzB 336	8 Pgi 250	336	141	22,3	17,6
9 PzB 378 *	9 Pgi 250	378	157	25,2	19,9
10 PzB 420 *	10 Pgi 250	420	173	27,6	21,8
11 PzB 462 *	11 Pgi 250	462	189	30,0	23,7

55Ah/plate

h1 = 399, h2 = 423 mm | length = b = 157,5 mm

CELL TYPE	TOPLA DESIGNATION	CAPACITY 5h	WIDTH mm	WEIGHT with acid	WEIGHT dry (kg)
2 PzB 110	2 Pgi 310	110	45	7,6	6,1
3 PzB 165	3 Pgi 310	165	61	10,5	8,5
4 PzB 220	4 Pgi 310	220	77	13,5	11,0
5 PzB 275	5 Pgi 310	275	93	16,5	13,5
6 PzB 330	6 Pgi 310	330	109	19,6	15,9
7 PzB 385	7 Pgi 310	385	125	22,6	18,4
8 PzB 440	8 Pgi 310	440	141	25,6	20,8
9 PzB 495 *	9 Pgi 310	495	157	29,1	23,8
10 PzB 550 *	10 Pgi 310	550	173	32,1	26,3
11 PzB 605 *	11 Pgi 310	605	189	35,2	28,7

65Ah/plate

h1 = 453, h2 = 477 mm | length = b = 157,5 mm

CELL TYPE	TOPLA DESIGNATION	CAPACITY 5h	WIDTH mm	WEIGHT with acid	WEIGHT dry (kg)
2 PzB 130	2 Pgi 360	130	45	8,2	6,8
3 PzB 195	3 Pgi 360	195	61	12,0	10,1
4 PzB 260	4 Pgi 360	260	77	15,5	13,0
5 PzB 325	5 Pgi 360	325	93	19,0	16,0
6 PzB 390	6 Pgi 360	390	109	22,6	18,9
7 PzB 455	7 Pgi 360	455	125	26,1	21,8
8 PzB 520	8 Pgi 360	520	141	29,6	24,5
9 PzB 585 *	9 Pgi 360	585	157	33,6	27,9
10 PzB 650 *	10 Pgi 360	650	173	37,2	30,6
11 PzB 715 *	11 Pgi 360	715	189	40,7	33,3

75Ah/plate

h1 = 513, h2 = 537 mm | length = b = 157,5 mm

CELL TYPE	TOPLA DESIGNATION	CAPACITY 5h	WIDTH mm	WEIGHT with acid	WEIGHT dry (kg)
2 PzB 150	2 Pgi 413	150	45	10,0	7,5
3 PzB 225	3 Pgi 413	225	61	13,9	10,8
4 PzB 300	4 Pgi 413	300	77	17,8	14,1
5 PzB 375	5 Pgi 413	375	93	21,6	17,5
6 PzB 450	6 Pgi 413	450	109	25,6	20,9
7 PzB 525	7 Pgi 413	525	125	29,6	24,1
8 PzB 600	8 Pgi 413	600	141	33,5	27,4
9 PzB 675 *	9 Pgi 413	675	157	38,2	31,1
10 PzB 750 *	10 Pgi 413	750	173	42,3	34,2
11 PzB 825 *	11 Pgi 413	825	189	46,4	37,3

86Ah/plate

h1 = 567, h2 = 591 mm | length = b = 157,5 mm

CELL TYPE	TOPLA DESIGNATION	CAPACITY 5h	WIDTH mm	WEIGHT with acid	WEIGHT dry (kg)
2 PzB 172	2 Pgi 450	172	45	10,7	8,3
3 PzB 258	3 Pgi 450	258	61	15,0	11,8
4 PzB 344	4 Pgi 450	344	77	19,3	15,2
5 PzB 430	5 Pgi 450	430	93	23,7	18,6
6 PzB 516	6 Pgi 450	516	109	28,1	22,0
7 PzB 602	7 Pgi 450	602	125	32,6	25,4
8 PzB 688	8 Pgi 450	688	141	37,1	28,8
9 PzB 774 *	9 Pgi 450	774	157	42,3	32,9
10 PzB 860 *	10 Pgi 450	860	173	46,9	36,3
11 PzB 946 *	11 Pgi 450	946	189	51,4	39,7

100Ah/plate

h1 = 608 h2 = 632 mm | length = b = 157,5 mm

CELL TYPE	TOPLA DESIGNATION	CAPACITY 5h	WIDTH mm	WEIGHT with acid	WEIGHT dry (kg)
2 PzB 200	2 Pgi 492	200	45	11,8	9,4
3 PzB 300	3 Pgi 492	300	61	16,6	13,5
4 PzB 400	4 Pgi 492	400	77	21,5	17,5
5 PzB 500	5 Pgi 492	500	93	26,4	21,6
6 PzB 600	6 Pgi 492	600	109	31,5	25,6
7 PzB 700	7 Pgi 492	700	125	36,4	29,7
8 PzB 800	8 Pgi 492	800	141	41,4	33,7
9 PzB 900 *	9 Pgi 492	900	157	47,1	38,6
10 PzB 1000 *	10 Pgi 492	1000	173	52,0	42,7
11 PzB 1100 *	11 Pgi 492	1100	189	56,9	46,7

108Ah/plate

h1 = 688, h2 = 712 mm | length = b = 157,5 mm

CELL TYPE	TOPLA DESIGNATION	CAPACITY 5h	WIDTH mm	WEIGHT with acid	WEIGHT dry (kg)
2 PzB 216	2 Pgi 530	216	45	13,5	9,9
3 PzB 324	3 Pgi 530	324	61	18,9	14,3
4 PzB 432	4 Pgi 530	432	77	24,3	18,7
5 PzB 540	5 Pgi 530	540	93	29,7	23,2
6 PzB 648	6 Pgi 530	648	109	35,1	27,6
7 PzB 756	7 Pgi 530	756	125	40,5	32,1
8 PzB 864	8 Pgi 530	864	141	45,9	36,5
9 PzB 972 *	9 Pgi 530	972	157	52,0	41,6
10 PzB 1080 *	10 Pgi 530	1080	173	57,4	46,0
11 PzB 1188 *	11 Pgi 530	1188	189	62,8	50,4



TOPLA GEL TRACTION

Maintenance free TOPLA Gel batteries are high sophisticated traction batteries in the family of TOPLA motive power products.

Sealed TOPLA Gel batteries are produced in VRLA Gel technology (Valve Regulated Lead Acid batteries with electrolyte in the form of gel) according to EN 60254-2 standard.

They can be used in all kind of electrical appliances like forklift trucks, electric road machines, cleaning machines, etc.

Due to its high operational safety and high degree of environmental friendliness TOPLA Gel battery is particularly suitable for applications in pharmaceutical, food, chemical and similar industries.

Main characteristics

- MAINTENANCE FREE
- INCORPORATED VALVES IN EXHAUST TUBES PREVENT CORROSIVE GAS RELEASE
- EXTREMELY LOW SELF-DISCHARGE
- EXTREMELY LOW GASSING DURING OPERATION
- MAINTENANCE ERRORS ARE MINIMIZED
- NO ELECTROLYTE LEAKAGE IN CASE OF CELL DAMAGE
- NO CONTAMINATION OR CORROSION DUE TO LEAKING ELECTROLYTE



PzV STANDARD CHARACTERISTIC DATA

55Ah/plate

h1 = 340, h2 = 350 mm | length = b = 198 mm

CELL TYPE	CAPACITY C5	WIDTH mm	WEIGHT with acid
2 PzV 110	110	47	9,3
3 PzV 165	165	65	12,7
4 PzV 220	220	83	16,5
5 PzV 275	275	101	20,1
6 PzV 330	330	119	23,8
7 PzV 385	385	137	27,4

100Ah/plate

h1 = 563, h2 = 573 mm | length = b = 198 mm

CELL TYPE	CAPACITY C5	WIDTH mm	WEIGHT with acid
2 PzV 200	200	47	14,7
3 PzV 300	300	65	21,6
4 PzV 400	400	83	27,8
5 PzV 500	500	101	34,3
6 PzV 600	600	119	40,6

70Ah/plate

h1 = 402, h2 = 412 mm | length = b = 198 mm

CELL TYPE	CAPACITY C5	WIDTH mm	WEIGHT with acid
2 PzV 140	140	47	10,8
3 PzV 210	210	65	15,5
4 PzV 280	280	83	19,7
5 PzV 350	350	101	24,2
6 PzV 420	420	119	29,1

120Ah/plate

h1 = 720, h2 = 730 mm | length = b = 198 mm

CELL TYPE	CAPACITY C5	WIDTH mm	WEIGHT with acid
2 PzV 240	240	47	19,7
3 PzV 360	360	65	27,4
4 PzV 480	480	83	35,3
5 PzV 600	600	101	42,1
6 PzV 720	720	119	50,0

80Ah/plate

h1 = 472, h2 = 482 mm | length = b = 198 mm

CELL TYPE	CAPACITY C5	WIDTH mm	WEIGHT with acid
2 PzV 160	160	47	12,7
3 PzV 240	240	65	18,1
4 PzV 320	320	83	23,6
5 PzV 400	400	101	29,0
6 PzV 480	480	119	35,0

PzVB STANDARD

61Ah/plate

h1 = 472, h2 = 486 mm | length = b = 157,5 mm

CELL TYPE	CAPACITY C5	WIDTH mm	WEIGHT with acid
2 PzVB 122	122	45	9,7
3 PzVB 183	183	61	13,5
4 PzVB 244	244	77	16,9

71Ah/plate

h1 = 516, h2 = 530 mm | length = b = 157,5 mm

CELL TYPE	CAPACITY C5	WIDTH mm	WEIGHT with acid
2 PzVB 142	142	45	10,6
3 PzVB 213	213	61	14,8
4 PzVB 284	284	77	18,5

81Ah/plate

h1 = 611, h2 = 625 mm | length = b = 157,5 mm

CELL TYPE	CAPACITY C5	WIDTH mm	WEIGHT with acid
2 PzVB 170	170	45	11,8
3 PzVB 255	255	61	16,1
4 PzVB 340	340	77	20,7

TOPLA AQUALESS TRACTION PzRM BATTERIES

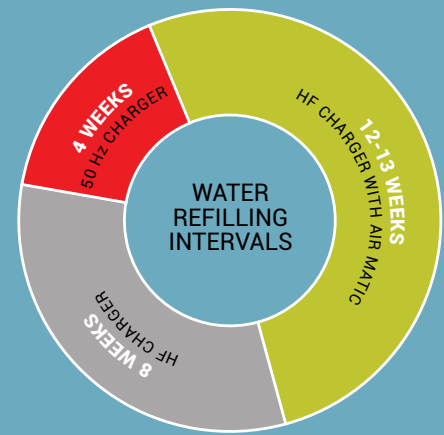

TOPLA AQUALESS	AQUA 1	AQUA 2	AQUA 3
Refilling Interval in weeks	4	8	12-13
Charger	50 Hz	HF	HF + Air Matic
Charging Factor	1.2	1.10-1.11	1.07-1.08
Electrolyte Level indicator	SERIAL	SERIAL	SERIAL
Central Water Filling System	OPTIONAL	OPTIONAL	OPTIONAL
Air Matic	OPTIONAL	OPTIONAL	SERIAL

Condition: water refilling intervals are based on 80% DOD - 1 cycle per day; 5 days per week

Water refill interval is efficiently prolonged.

Main advantages

- WATER REFILL INTERVAL IS EFFICIENTLY PROLONGED
- REDUCED WATER CONSUMPTION
- LOW MAINTENANCE AND REDUCED OPERATIONAL COSTS
- REDUCED CHARGING FACTOR
- 50 TO 80% REDUCED GAS RELEASE
- AND VENTILATION REQUIREMENTS
- 20 TO 30% LESS CHARGING TIME
- COST SAVING DUE TO LOWER ENERGY CONSUMPTION FROM 10 TO 20%
- REDUCED OPERATING TEMPERATURES

Electrolyte density at 30 °C: 1,29 ± 0,01 kg/l. Weight tolerance is ± 5 %.

Cells from 7 to 10 PzRM types are available with 2 and 4 poles. For 4 poles, please specify in your order.

10 PzRM 1400, 10 PzRM 1550 and all 12 PzRM cells are available with 4 poles only.

Cells available only with 4 poles are signed with *.



80Ah/plate

h1 = 402, h2 = 425 mm | length = b = 198 mm

CELL TYPE	CAPACITY C5	WIDTH mm	WEIGHT kg
2 PzRM 160	160	47	10,2
3 PzRM 240	240	65	14,5
4 PzRM 320	320	83	18,7
5 PzRM 400	400	101	22,9
6 PzRM 480	480	119	27,1
7 PzRM 560	560	137	31,3
8 PzRM 640	640	155	35,5
9 PzRM 720	720	173	39,7
10 PzRM 800	800	191	43,9
12 PzRM 960 *	960	227	52,6

90Ah/plate

h1 = 472, h2 = 495 mm | length = b = 198 mm

CELL TYPE	CAPACITY C5	WIDTH mm	WEIGHT kg
2 PzRM 180	180	47	11,6
3 PzRM 270	270	65	16,6
4 PzRM 360	360	83	21,4
5 PzRM 450	450	101	26,2
6 PzRM 540	540	119	31,0
7 PzRM 630	630	137	35,8
8 PzRM 720	720	155	40,6
9 PzRM 810	810	173	45,4
10 PzRM 900	900	191	50,2
12 PzRM 1080 *1080		227	60,1

105Ah/plate

h1 = 515, h2 = 538 mm | length = b = 198 mm

CELL TYPE	CAPACITY C5	WIDTH mm	WEIGHT kg
2 PzRM 210	210	47	13,3
3 PzRM 315	315	65	18,3
4 PzRM 420	420	83	23,7
5 PzRM 525	525	101	29,1
6 PzRM 630	630	119	34,5
7 PzRM 735	735	137	39,9
8 PzRM 840	840	155	45,3
9 PzRM 945	945	173	50,7
10 PzRM 1050	1050	191	56,4
12 PzRM 1260 *1260		227	67,2

115Ah/plate

h1 = 545, h2 = 568 mm | length = b = 198 mm

CELL TYPE	CAPACITY C5	WIDTH mm	WEIGHT kg
2 PzRM 230	230	47	14,0
3 PzRM 345	345	65	19,5
4 PzRM 460	460	83	25,0
5 PzRM 575	575	101	30,6
6 PzRM 690	690	119	36,2
7 PzRM 805	805	137	41,8
8 PzRM 920	920	155	47,4
9 PzRM 1035	1035	173	53,2
10 PzRM 1150	1150	191	58,9
12 PzRM 1380 *1380		227	70,1

125Ah/plate

h1 = 570, h2 = 593 mm | length = b = 198 mm

CELL TYPE	CAPACITY C5	WIDTH mm	WEIGHT kg
2 PzRM 250	250	47	14,5
3 PzRM 375	375	65	20,5
4 PzRM 500	500	83	26,5
5 PzRM 625	625	101	32,5
6 PzRM 750	750	119	38,5
7 PzRM 875	875	137	44,5
8 PzRM 1000	1000	155	50,5
9 PzRM 1125	1125	173	56,8
10 PzRM 1250	1250	191	62,8
12 PzRM 1500 *1500		227	74,8

140Ah/plate

h1 = 686, h2 = 709 mm | length = b = 198 mm

CELL TYPE	CAPACITY C5	WIDTH mm	WEIGHT kg
2 PzRM 280	280	47	20,6
3 PzRM 420	420	65	25,3
4 PzRM 560	560	83	32,2
5 PzRM 700	700	101	39,5
6 PzRM 840	840	119	46,7
7 PzRM 980	980	137	54,0
8 PzRM 1120	1120	155	61,2
9 PzRM 1260	1260	173	68,8
10 PzRM 1400 *1400		191	76,0
12 PzRM 1680 *1680		227	90,5

155Ah/plate

h1 = 720, h2 = 743 mm | length = b = 198 mm

CELL TYPE	CAPACITY C5	WIDTH mm	WEIGHT kg
2 PzRM 310	310	47	21,5
3 PzRM 465	465	65	26,1
4 PzRM 620	620	83	33,5
5 PzRM 775	775	101	41,1
6 PzRM 930	930	119	48,9
7 PzRM 1085	1085	137	56,7
8 PzRM 1240	1240	155	64,5
9 PzRM 1395	1395	173	72,8
10 PzRM 1550 *1550		191	80,6
12 PzRM 1860 *1860		227	96,2

- water refilling interval up to 13 weeks (at normal duty applications with 80% DOD C5, 1 cycle per day; 5 days per week, Electrolyte T=30°C)
- for these batteries proper chargers must be used
- cells are equipped with Electrolyte Mixing system
- batteries are assembled with Central Water Filling system
- each battery has an Electrolyte Level Sensor
With its red light it gives signal to the user when water refilling is needed

With proven PzS technology using tubular plates in combination with an adjusted charging regime results in extended watering intervals. TOPLA PzRM cells are manufactured and tested according to EN60254-1 and IEC254-1.

Battery application.

Traction batteries TOPLA of type PzS and PzB are according to EN 60254-1,2 and IEC 254-1,2 and are appropriated for propulsion of different electrical machines (forklifts, mine locomotives, etc.).

One of the very important production part of your company is internal logistics. We are introducing our traction batteries TOPLA which have been satisfying the most demanding users for more than half a century. **Batteries are known by their: high capacity, long life-time, resistance to vibrations, short charging times, low consumption of distilled water, simple maintenance.**

Sales department

T: +386 (0)2 8702 300
F: +386 (0)2 8702 335

Service department

T: +386 (0)2 8700 211
F: +386 (0)2 8700 234



TAB d. d.,
Polena 6, SI-2392 Mežica, Slovenia
info@tab.si, www.tab.si

AQUAMATIC



AIR MATIC



LEVEL CHECK



MONITORING SYSTEM



We highly recommend the use of additional systems:

- **CENTRAL WATER FILLING SYSTEM (AQUAMATIC):**
Each cell is equipped with aquamatic plug, combined with tubes and water drums. At the same time enables central water filling for whole the battery. Enables quick and precise service of whole battery under any working conditions.
- **ELECTROLYTE MIXING SYSTEM (AIRMATIC)**
which allows faster charging of battery. Each cell is equipped with special airmixing tube. Tubes are combined together with PVC tubes and connected trough connector to air compressor. Air compressor is already built in charger or can be installed additionally into ordinary charger with charging principle IU; WoWa. Air consumption per hour is 60 litres/cell by operational pressure 0,2 Bars. System is operating all the time during the charging. System allows an electric vehicle to be in operation for 16 hours without changing the battery.
- **CAPACITIVE BATTERY ELECTROLYTE LEVEL SENSOR**
which with clearly visible greenlight indicates electrolyte at proper specified level. Flashing red light indicates that the electrolyte level is bellow minimum and battery needs to be refilled with demineralised water to avoid permanent damage of the battery.
- **BATTERY MONITORING SYSTEM**
allows you to see real time status of your batteries. Our battery monitoring system is able to provide:
 - full statistical analysis of battery's performance (capacity, load levels, charging and discharging characteristics);
 - breakdown of each machine's performance (when and how it was used, when it was charged, etc.);
 - real time information and alerts via email or phone.